

09 DRIP EDGE WITH GUTTER
A-303 SCALE: 3" = 1'-0"

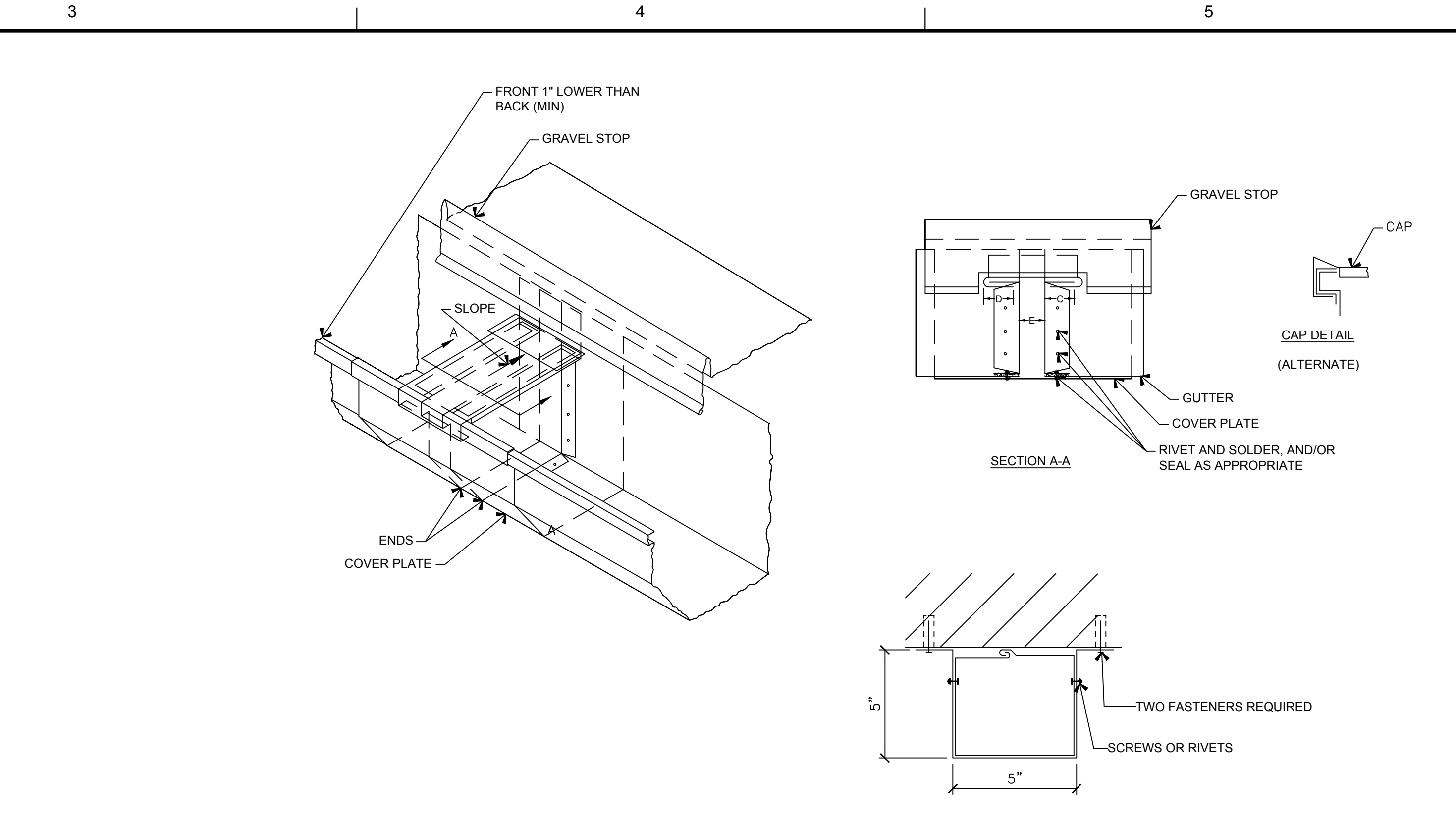

10 METAL EDGE WITH GUTTER
A-303 SCALE: 3" = 1'-0"

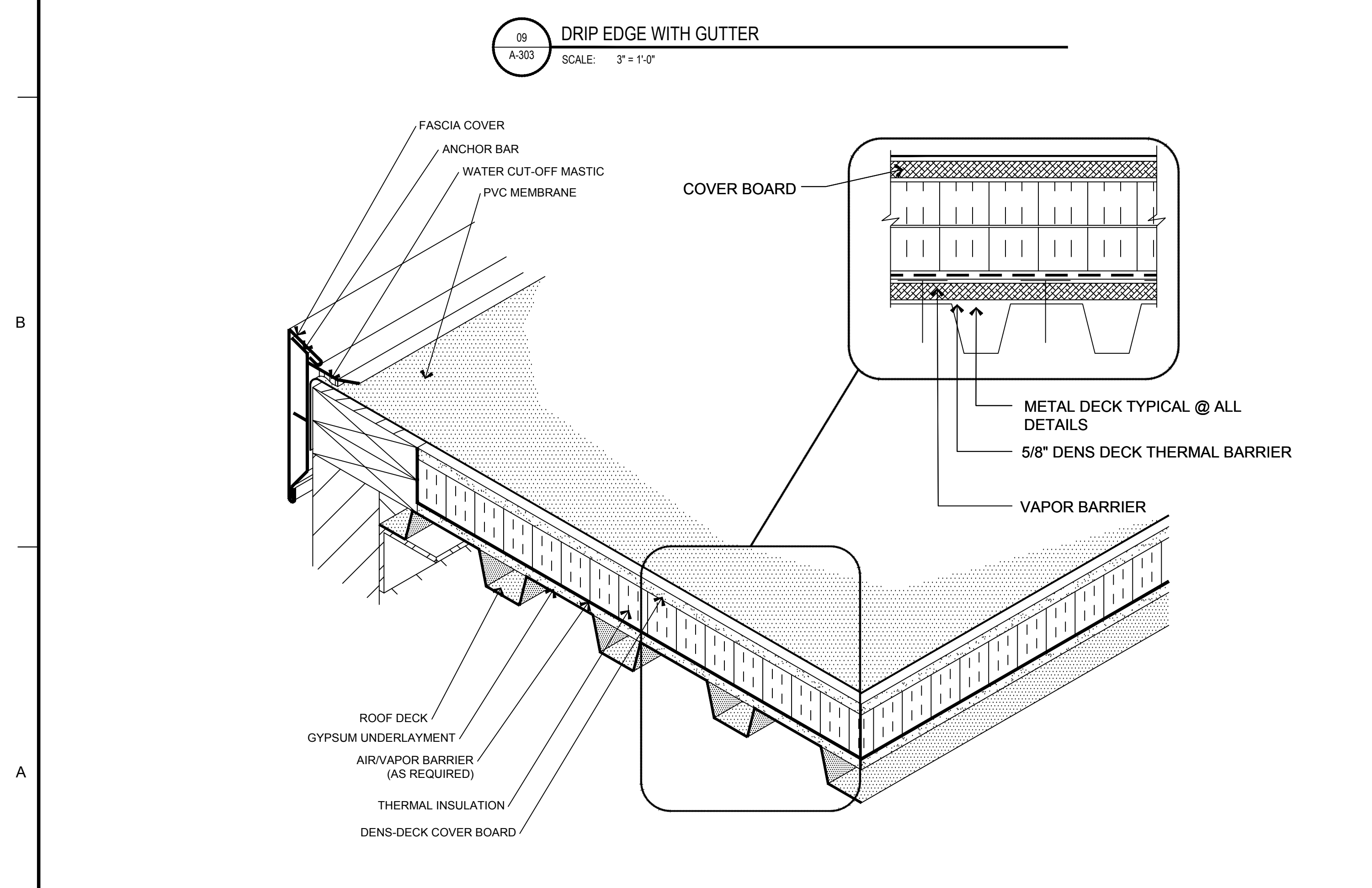

11 PRE-ENGINEERED EDGE FASCIA
A-303 SCALE: 3" = 1'-0"

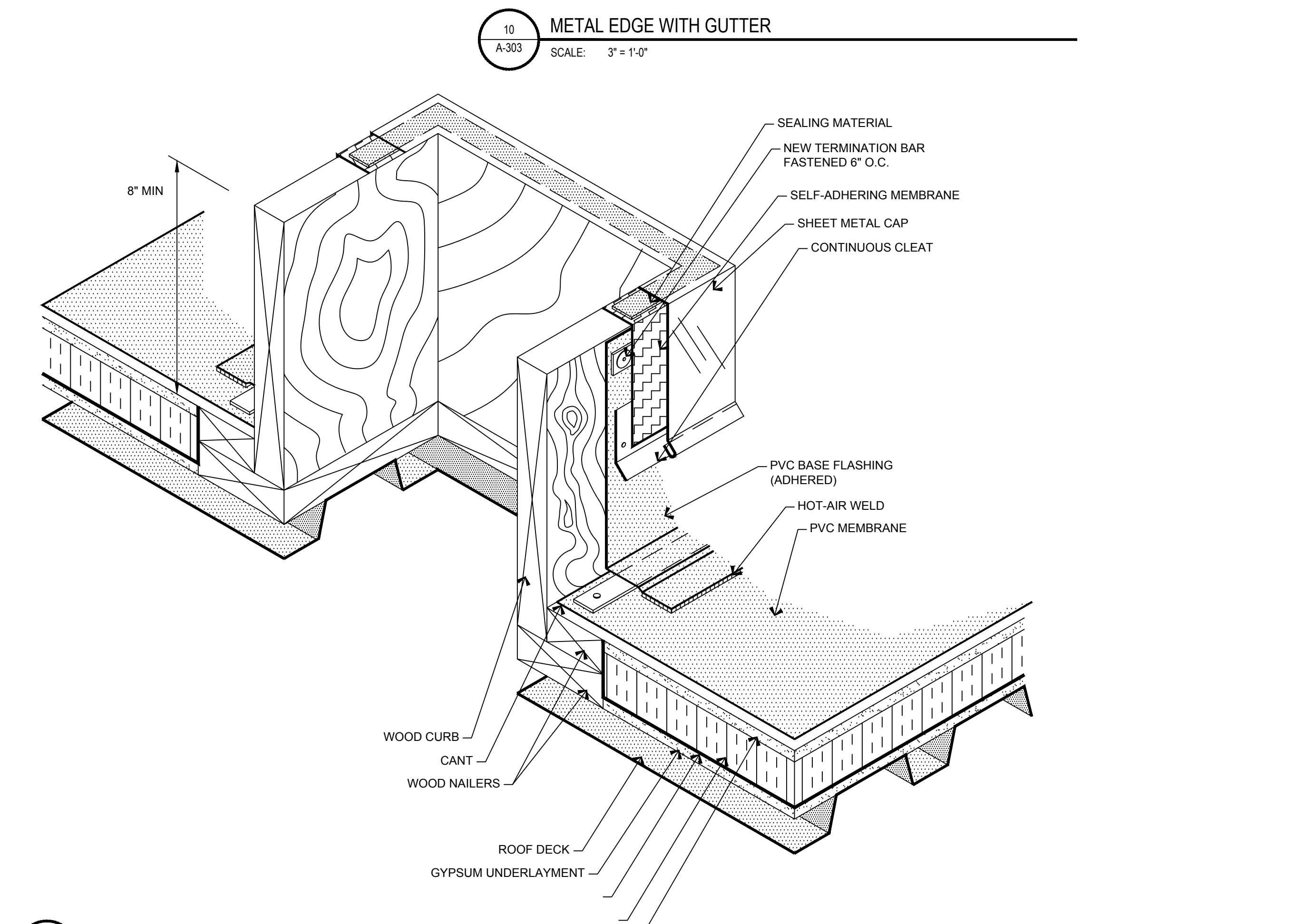

12 CURBED PENETRATION
A-303 SCALE: 3" = 1'-0"

DATE	DESCRIPTION	DATE	APPRO

DESIGNED BY:	CHKD BY:	SOLICITATION NO.:	
U.S. ARMY CORPS OF ENGINEERS	JM	W912QR51844314	
LOUISVILLE DISTRICT	BH	CONTRACT NO.:	
LOUISVILLE, KENTUCKY		W912QR-14-D-0020	
		FILE NUMBER:	

NATIONAL ROOFING INITIATIVE (NRI) FY 2017 INSPECTION PROJECT #1 M1029 - SOUTHFIELD, MI P2 #462827	DETAILS
--	---------

